

7203-001

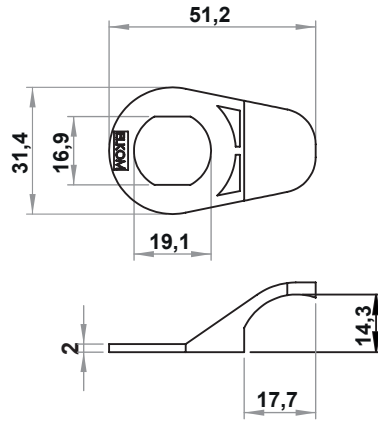

7203-002

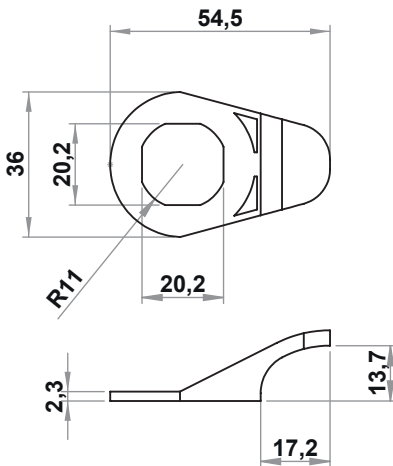

7203-003

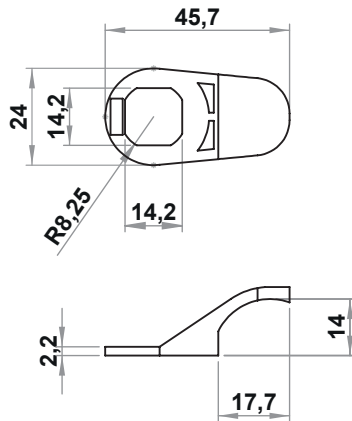

7203-004



Quarter Turns

Material



Housing: Polyamide (PA)

Important Note:

When fingerpull is used, it is necessary to note that the GH dimension will become smaller 2mm.

Because of this reason, the H dimension of the chosen cam, should be +2mm deeper.

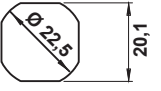
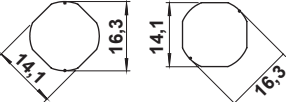
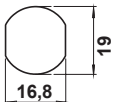
7203 - Finger Pull

| Cutout | Product family can be used | Item Number |
|---|--------------------------------------|-------------|
|  | 1800, 1817, 1842 1801, 1011, 1001 | 7203 - 001 |
|  | 1814, 1824, 1834 | 7203 - 002 |
|  | 1122, 1044, 1045 1544, 1545 | 7203 - 003 |
|  | 1004, 1890 | 7203 - 004 |

RoHS